



Fun Fly & Picnic Sept 9th

Next Sunday is our annual Fun Fly & BBQ!
As always, good people, guaranteed fun and lots of food.

The club is providing the brats, hamburgers and soft drinks, paper plates etc. We ask each of you to bring one side dish, chips, or dessert.



Mark Chadwich is conjuring up some fun fly events to challenge your aviator skills.

I heard a rumor about combat flying – Anyone interested? Of course there will be limbo – snagged several flyers last year! Don't forget to bring your pylon racer for the main event. See the next page for some pictures from last year's fun fly.

Important letter from Charlie Bauer to AMA District VI Clubs on page 4.

SAFETY FIRST

EVERY MEMBER IS A DEPUTY SAFETY OFFICER

Club Officers

President	Scott Calvin	xx
Vice President	Craig Watson	x
Treasurer	Ron Moidel	x
Secretary	Earl Westergom	x
Safety Officer	Ryan Von Talge	x
Membership	Cliff Wisser	x

Board Members

Roger Watson, Cliff Wisser, Dwight Hayden & Tom King

Club Instructors

Scott Calvin	x
Tom King	x
Ron Moidel	x

Helicopter Training

Scott Fitzgerald	x
Ryan Von Talge	x

Aviation Truism (*Mostly True*)

"Never fly in the same cockpit with someone braver than you."

Wise "old" pilot

Next Club Meeting & Fun Fly

Sunday, Sept 9th at 3PM

Fun Fly begins at 1PM

Our web site is

2006 Fun Fly and BBQ



ITSY-BITSY DRONE

Check out the following RC technology
The "Wasp Micro Air Vehicle" (MAV)



There are now dozens of different types of drones in the Pentagon's arsenal. But you'd be hard-pressed to find one smaller than this Wasp Micro Air Vehicle (MAV), now being tested aboard the Nimitz Carrier Strike Group off Southern California.

"The Wasp has two cameras - one forward and one aft - that collect and feed live video or other information. It's designed to follow a programmed or relayed route using Global Positioning System waypoints or other navigational systems," C4ISR Journal says.

Last month, researchers on the Nimitz's ships "launched several of the 7-ounce, 13-inch planes." Sailors there will be taking "the Wasp along on its upcoming deployment used it for several missions, including maritime interdiction and force protection. Micro UAVs might help in situations in which ships do not have helicopters available... 'It has the potential to save lives during boardings,' said Lt. Cmdr. Joseph Roth, the Nimitz group's communications officer."

DUCTED FAN MAV

Has a helicopter-like ability to hover

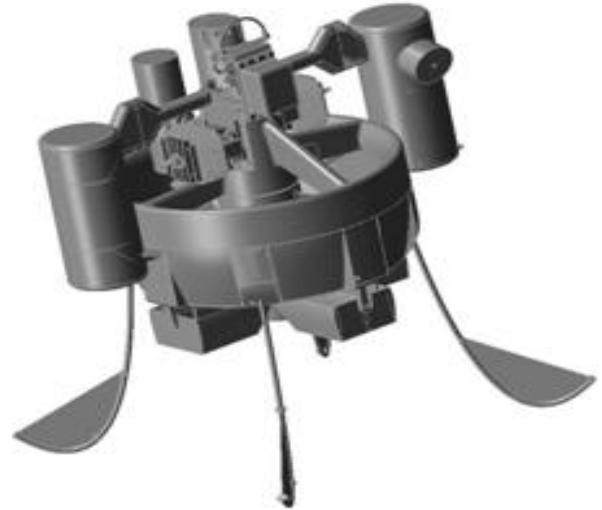

Meanwhile, DARPA and Honeywell are teaming up for a second, slightly larger MAV program. Weighing in at about 12 pounds, the gallon-of-apple-juice-sized drone is meant to fit inside a soldier's (already overstuffed) backpack.

The idea is that the MAV will give a small infantry unit the ability to see over the next hill, or around the next corner. That's pretty much what the hand-launched Raven and Dragon Eye drones do today. But this MAV uses ducted fan propulsion, giving it a helicopter-like ability to hover over a valley or alleyway -- or even land on a nearby rooftop, and watch a battle unfold.

Ray Todd recommends checking out the B-29 at the following site

Here's a video of an amazing piece of handiwork by a bunch of very talented guys. This B-29 aircraft runs on four chainsaw motors. You can just imagine how much time, effort, skill, and money these guys have put into this thing. It carries a space explorer aloft under its wing.

See: <http://users.skynet.be/fa926657/files/B29.wmv>

AMA News



www.modelaircraft.org

Free* JR or Airtronics Buddy Box!

Thanks to the AMA, any new adult member can receive either of these buddy boxes with his new membership!

Get your buddy started right. Recommend he join AMA, and along with his new AMA membership he will receive a JR or Airtronics buddy-box transmitter at no extra charge.

Oh yes, the fine print * \$7.95 shipping and handling charge with 8-12 weeks for delivery.

AMA's Ambassador Program

Sign up three new qualifying members and your next membership will be at no charge.

For details go to: WWW.modelaircraft.org/promos/1

"FREEBIE" Quiet Flyer Magazine

Earl still has free copies of the Quiet Flyer magazine to hand out. Let him know if you would like one. I hate to throw them out!!

F3C Helicopter Judges Training Course/Presentation Is Available

This presentation is in PDF format. It was developed by Swiss FAI judge Juerg Schmitter. It is an excellent presentation for those interested in judging the FAI F3C Helicopter class. Pilots will also find the presentation useful. Take a look at:

<http://www.modelaircraft.org/comp/competition.htm>

PEKIN RC Club 27th ANNUAL BIG BIRD FLY-IN 9/16/07

Features 1/3 and 1/4 scale WW1, WW2 war birds along with many other IMAA legal planes. IMAA event. For information contact: snjspeerly@insightbb.com Steven T Speerly

Open Letter from Charlie Bauer AMA District VI VP

Subject: AMA President's Election

Yes, I am the VP for this district, but this letter has nothing to do with that. This letter is being sent to you at no expense to the AMA.

I have been a member of the AMA since 1938. I have seen a number of presidents of the organization, and I firmly believe that Dave Mathewson is the best choice for our next president.

He has been an outstanding VP for district II. As president, he will keep the AMA a financially strong organization with the technology that will move our organization ahead.

I ask you to vote for Dave Mathewson when the ballots arrive.

Thanks for your support....and keep flying,
Charlie

2007 Track Season

Please remember that we are "guests" of SIUE and that flying is not authorized during track events - scheduled or unscheduled. Safety First.

Wed Sept 5	Tiger Classic Invitational
Sat, Sept. 8	Liberty Invitational
Tue, Sept 11	St. Louis
Sat, Sept 15	Edwardsville Invitational
Tue, Sept 18	Edw. Lincoln Invitational
Wed, Sept 26	Conference Meet
Tue Oct 2	Madison County Meet
Fri, Oct 12	SW Conf Meet
Mon Oct 15	Tiger Finale
Oct 20 and 27	Regional Championships